

TYPICAL BREAKER WIRING

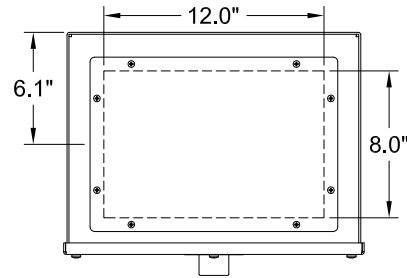

CIRCUIT BREAKER SUMMARY

BREAKER TYPE	BREAKER MODEL	TRIP	AIC	WIRE RANGE
CUTLER HAMMER SERIES G	LGEDC3XXX	500-600A	35K @ 600VDC	(2) 2 - 500
CUTLER HAMMER SERIES C	HMDLDC3700	700A	35K @ 600VDC	(2) 1 - 500
	HMDLDC3800	800A	35K @ 600VDC	(3) 3/0 - 400

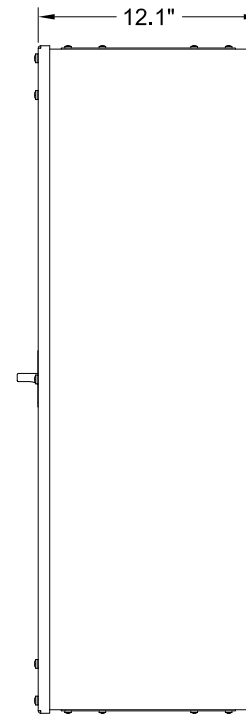
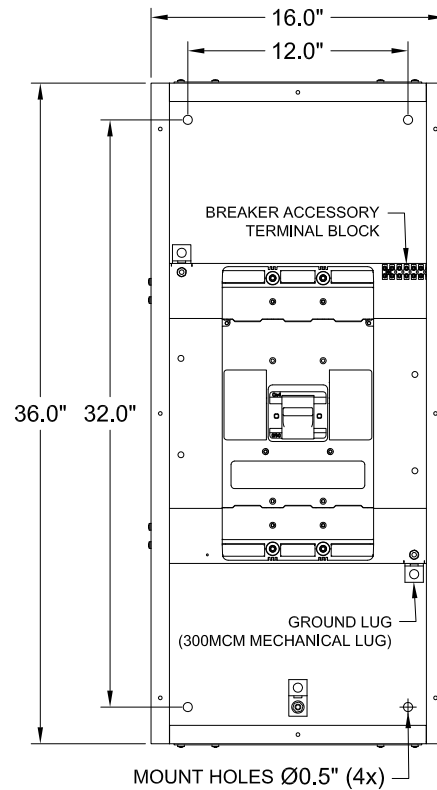
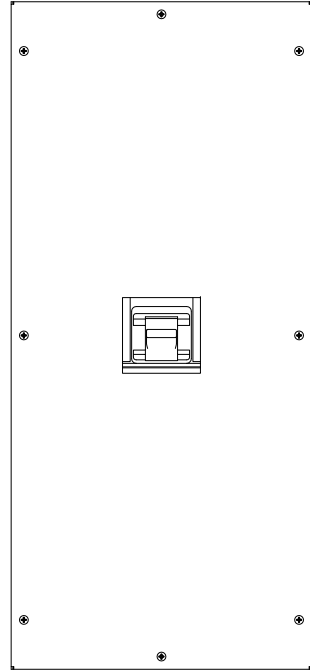

REMOVABLE GLAND PLATE TYP. TOP & BOTTOM

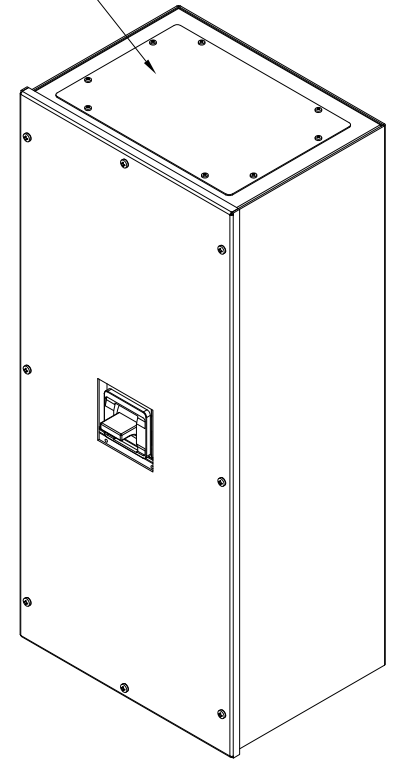

NOTES:

- APPROXIMATE WEIGHT: 130 LBS.
- ASSEMBLY IS UL LISTED TO UL 1778.
- NEMA 1 WALL MOUNT ENCLOSURE.
- THE BOX & COVER ARE CONSTRUCTED FROM HEAVY GAUGE COLD ROLLED STEEL.
- AVAILABLE IN MULTIPLE COLORS OF DURABLE & CORROSION RESISTANT POWDER COAT FINISH.

91822 SERIES WALL MOUNT UPS BATTERY DISCONNECT  
500 AMP - 800 AMP

THE INFORMATION CONTAINED IN THIS DRAWING IS THE SOLE PROPERTY OF C&C POWER, INC. ANY REPRODUCTION WITHOUT THE WRITTEN CONSENT OF C&C POWER, INC IS PROHIBITED.

DIMENSIONS ARE IN INCHES		INITIALS	DATE
TOLERANCES:	DECIMALS:	DRAWN CH	3/3/2014
ANGLES:	°	CHECKED CH	3/3/2014
.XX ±.13	±1"		
.XXX ±.082			
SCALE: NTS	SER: A	REV: 4	

**C&C POWER**  
ENGINEERED POWER PRODUCTS  
WWW.CCPOWER.COM  
© 2014 C&C POWER, INC.  
ALL RIGHTS RESERVED