

TOP VIEW

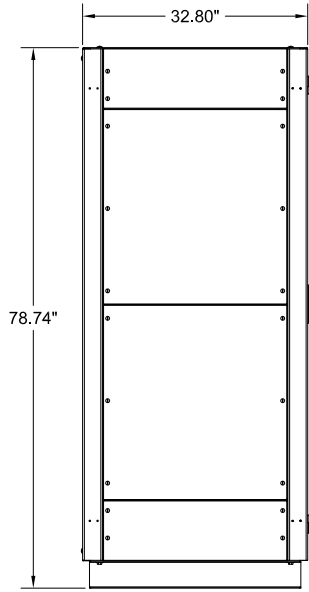

LEFT SIDE VIEW

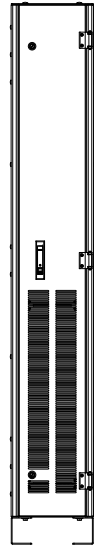

FRONT VIEW
(LEGS IN)

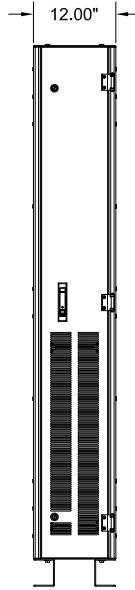

FRONT VIEW
(LEGS OUT)

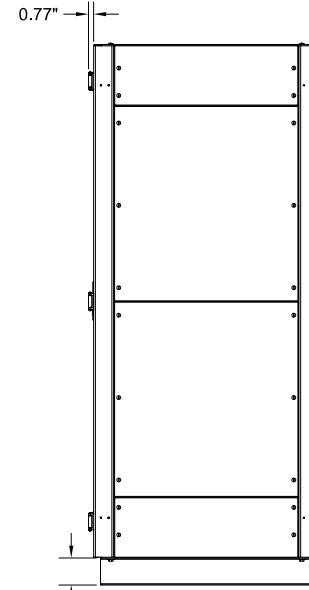

RIGHT SIDE VIEW

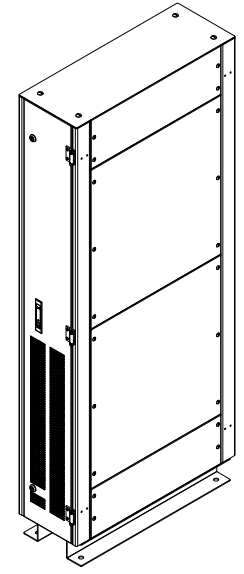

ISOMETRIC VIEW

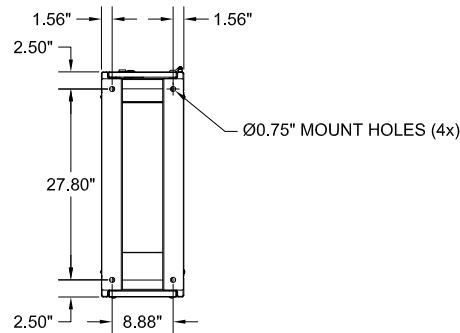

BOTTOM VIEW

NOTES:

APPROXIMATE WEIGHT: 275 LBS.

1. THE CABINET IS CONSTRUCTED FROM COLD ROLLED & GALVANIZED STEEL.
2. THE CABINET IS TO BE MOUNTED THROUGH THE Ø0.75" MOUNT HOLES IN THE CABINET LEGS. THE LEGS ARE FORMED FROM 10 GAUGE STEEL.
3. FINISH IS POWDER COAT ON ALL EXTERNAL AND VISIBLE SURFACES. INTERIOR PANELS AND MOUNT BRACKETS ARE GALVANIZED FINISH.
4. CABINET LEGS ARE REVERSIBLE FOR EASY ACCESS TO CABINET FLOOR MOUNTING HARDWARE.

90822-12B			
90822 SERIES LANDING CABINET WITH MAIN BREAKER			
DIMENSIONS ARE IN INCHES	INITIALS	DATE	THE INFORMATION CONTAINED IN THIS DRAWING IS THE SOLE PROPERTY OF C&C POWER, INC. ANY REPRODUCTION WITHOUT THE WRITTEN CONSENT OF C&C POWER, INC IS PROHIBITED.
TOLERANCES:	DRAWN JRL	10/28/10	
DECIMALS: .XX ±.13 .XXX ±.062	ANGLES: ±1"	CHECKED CH 10/28/10	
MATERIAL: SEE NOTES SHEET 1			
FINISH: SEE NOTES SHEET 1			
CAD GENERATED DRAWING DO NOT MANUALLY UPDATE			
SCALE: NTS: A	REV: 1	SHEET 1 OF 2	
C&C POWER ENGINEERED POWER PRODUCTS 949 N. Larch Ave. - Elmhurst, IL 60126			© 2010 C&C POWER, INC. ALL RIGHTS RESERVED

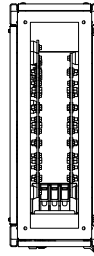

TOP VIEW
(COVER REMOVED)

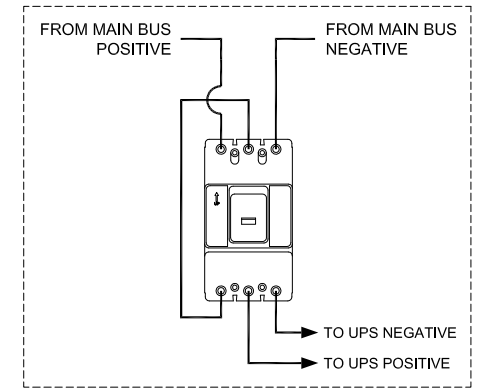

TYPICAL BREAKER WIRING

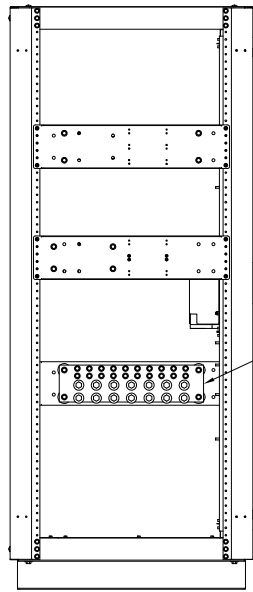

LEFT SIDE VIEW
(COVERS REMOVED)

MAIN BUS NEGATIVE

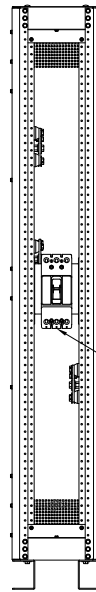

FRONT VIEW
(DOOR & COVERS
REMOVED)

MAIN BREAKER

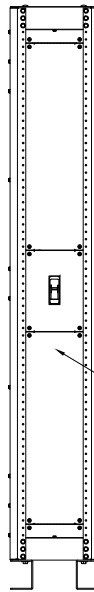

FRONT VIEW
(DOOR REMOVED)

REMOVABLE
DEAD-FRONTS

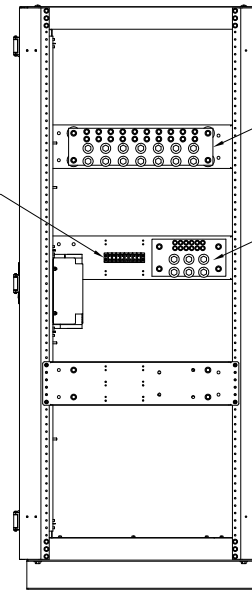

RIGHT SIDE VIEW
(COVERS REMOVED)

SYSTEM ACCESSORY
TERMINAL BLOCK

MAIN BUS POSITIVE

GROUND BUS

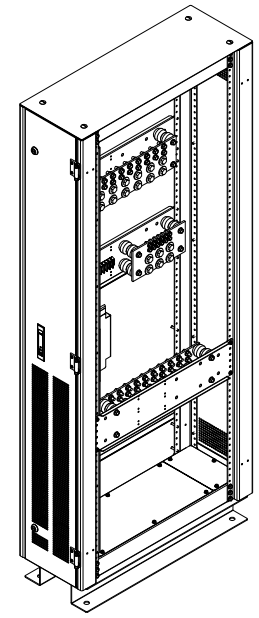

ISOMETRIC VIEW
(COVERS REMOVED)

NOTES:

1. MAIN BREAKER IS UL LISTED & AVAILABLE FROM 15 - 400 AMPS.
2. MAIN BREAKER IS FACTORY WIRED TO MAIN POSITIVE & NEGATIVE BUS.
3. MAIN LANDING BUS INPUT (FROM BATTERY CABINETS) IS PROVIDED WITH (10) TWO HOLE LANDINGS PER BUS ON 1" CENTERS TO ACCEPT Ø3/8" BOLTS. WILL ACCEPT LUGS WITH MAXIMUM TANG WIDTH OF 1-5/8".
4. GROUND BUS OUTPUT (TO MAIN GROUND) IS PROVIDED WITH (3) TWO HOLE LANDINGS ON 1-3/4" CENTERS TO ACCEPT Ø1/2" BOLTS. WILL ACCEPT LUGS WITH MAXIMUM TANG WIDTH OF 2".
5. GROUND BUS INPUT (FROM BATTERY CABINETS) IS PROVIDED WITH (6) TWO HOLE LANDINGS ON 1" CENTERS TO ACCEPT Ø5/16" BOLTS. WILL ACCEPT LUGS WITH MAXIMUM TANG WIDTH OF 3/4".
6. ALL TWO HOLE LANDINGS ARE CAPABLE OF ACCEPTING UP TO (2) TWO HOLE LUGS IN BACK TO BACK CONFIGURATION.
7. SYSTEM ACCESSORY BLOCK IS UL RECOGNIZED, 600V RATED.

90822-12B			
90822 SERIES LANDING CABINET WITH MAIN BREAKER			
DIMENSIONS ARE IN INCHES		INITIALS	DATE
TOLERANCES:		DRAWN	JHB
DECIMALS: .XX ±.13		CHECKED	CH
ANGLES: ±1"			03/23/11
MATERIAL: SEE NOTES SHEET 1			
FINISH: SEE NOTES SHEET 1			
CAD GENERATED DRAWING DO NOT MANUALLY UPDATE			
SCALE:	SHEET:	REV: 2	
		SHEET 2 OF 2	
THE INFORMATION CONTAINED IN THIS DRAWING IS THE SOLE PROPERTY OF C&C POWER, INC. ANY REPRODUCTION WITHOUT THE WRITTEN CONSENT OF C&C POWER, INC IS PROHIBITED.			C&C POWER ENGINEERED POWER PRODUCTS 949 N. Larch Ave. - Elmhurst, IL 60126 © 2010 C&C POWER, INC. ALL RIGHTS RESERVED

DRAWING # 90822-12B-S001-12 REV 2