

TOP VIEW

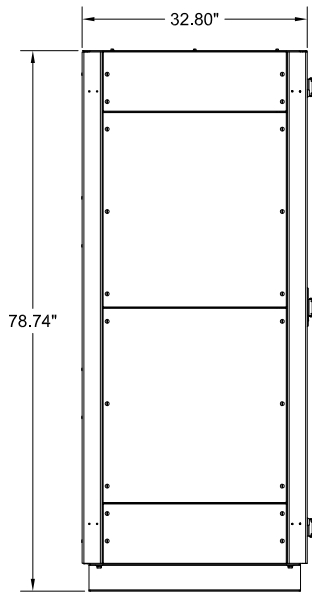

LEFT SIDE VIEW

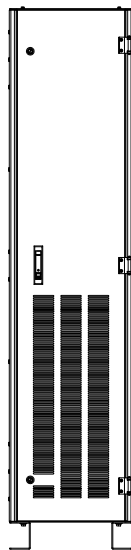

FRONT VIEW
(LEGS IN)

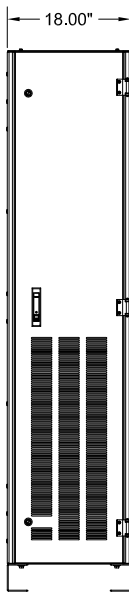

FRONT VIEW
(LEGS OUT)

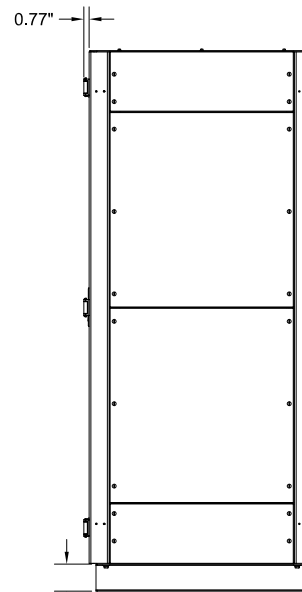

RIGHT SIDE VIEW

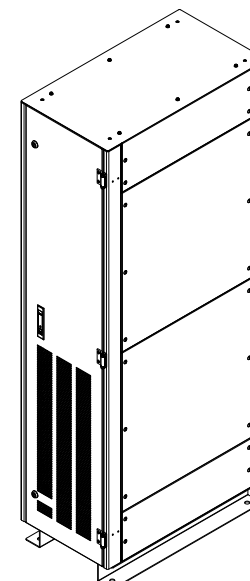

ISOMETRIC VIEW

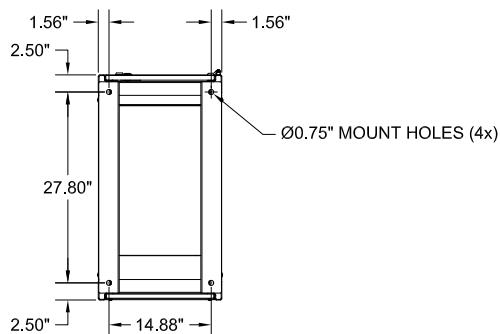

BOTTOM VIEW

NOTES:

APPROXIMATE WEIGHT: 305 LBS.

1. THE CABINET IS CONSTRUCTED FROM COLD ROLLED & GALVANIZED STEEL.
2. THE CABINET IS TO BE MOUNTED THROUGH THE Ø0.75" MOUNT HOLES IN THE CABINET LEGS. THE LEGS ARE FORMED FROM 10 GAUGE STEEL.
3. FINISH IS POWDER COAT ON ALL EXTERNAL AND VISIBLE SURFACES. INTERIOR PANELS AND MOUNT BRACKETS ARE GALVANIZED FINISH.
4. CABINET LEGS ARE REVERSIBLE FOR EASY ACCESS TO CABINET FLOOR MOUNTING HARDWARE.

| | | | |
|---|-------------|------------|--|
| 90822-18L | | | |
| 90822 SERIES LANDING CABINET | | | |
| DIMENSIONS ARE IN INCHES | | INITIALS | DATE |
| TOLERANCES: | | DRAWN JRL | 10/28/10 |
| DECIMALS: .XX ±.13 | ANGLES: ±1° | CHECKED CH | 10/28/10 |
| MATERIAL: SEE NOTES SHEET 1 | | | |
| FINISH: SEE NOTES SHEET 1 | | | |
| CAD GENERATED DRAWING DO NOT MANUALLY UPDATE | | | |
| SCALE: NTS | SIZE: A | REV: 1 | SHEET 1 OF 2 |
| THE INFORMATION CONTAINED IN THIS DRAWING IS THE SOLE PROPERTY OF C&C POWER, INC. ANY REPRODUCTION WITHOUT THE WRITTEN CONSENT OF C&C POWER, INC IS PROHIBITED. | | | C&C POWER ENGINEERED POWER PRODUCTS 949 N. Larch Ave. - Elmhurst, IL 60126 © 2010 C&C POWER, INC. ALL RIGHTS RESERVED |

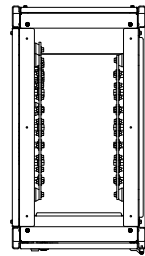

TOP VIEW
(COVER REMOVED)

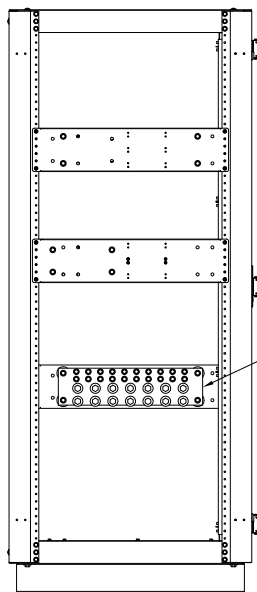

LEFT SIDE VIEW
(COVERS REMOVED)

MAIN BUS POSITIVE

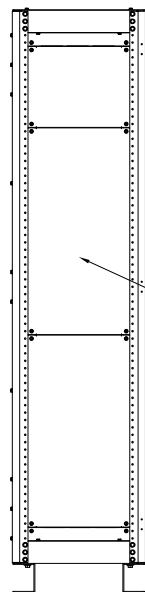

FRONT VIEW
(DOOR REMOVED)

REMOVABLE
DEAD-FRONTS

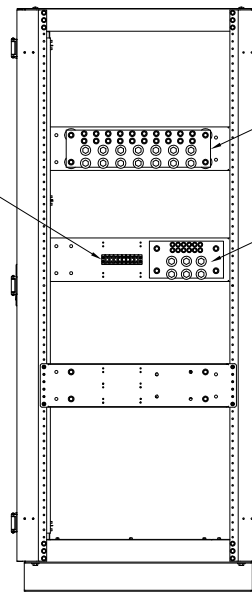

RIGHT SIDE VIEW
(COVERS REMOVED)

MAIN BUS NEGATIVE

GROUND BUS

SYSTEM ACCESSORY
TERMINAL BLOCK

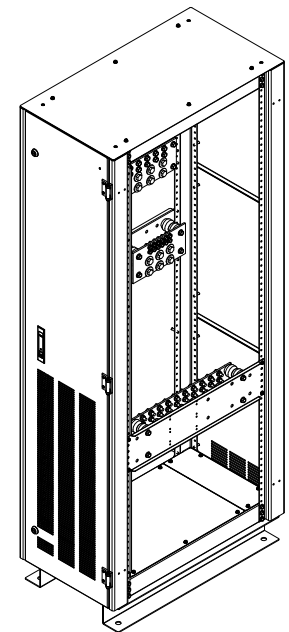

ISOMETRIC VIEW
(COVERS REMOVED)

NOTES:

1. AVAILABLE WITH 1250 AMP OR 2500 AMP RATED BUS BAR.
2. MAIN LANDING BUS OUTPUT (TO UPS) IS PROVIDED WITH (7) TWO HOLE LANDINGS PER BUS ON 1-3/4" CENTERS TO ACCEPT Ø1/2" BOLTS. WILL ACCEPT LUGS WITH MAXIMUM TANG WIDTH OF 2-3/8".
3. MAIN LANDING BUS INPUT (FROM BATTERY CABINETS) IS PROVIDED WITH (10) TWO HOLE LANDINGS PER BUS ON 1" CENTERS TO ACCEPT Ø3/8" BOLTS. WILL ACCEPT LUGS WITH MAXIMUM TANG WIDTH OF 1-5/8".
4. GROUND BUS OUTPUT (TO MAIN GROUND) IS PROVIDED WITH (3) TWO HOLE LANDINGS ON 1-3/4" CENTERS TO ACCEPT Ø1/2" BOLTS. WILL ACCEPT LUGS WITH MAXIMUM TANG WIDTH OF 2".
5. GROUND BUS INPUT (FROM BATTERY CABINETS) IS PROVIDED WITH (6) TWO HOLE LANDINGS ON 1" CENTERS TO ACCEPT Ø5/16" BOLTS. WILL ACCEPT LUGS WITH MAXIMUM TANG WIDTH OF 3/4".
6. ALL TWO HOLE LANDINGS ARE CAPABLE OF ACCEPTING UP TO (2) TWO HOLE LUGS IN BACK TO BACK CONFIGURATION.
7. SYSTEM ACCESSORY BLOCK IS UL RECOGNIZED, 600V RATED.

| | | | |
|---|-------------|------------|--|
| 90822-18L | | | |
| 90822 SERIES LANDING CABINET | | | |
| DIMENSIONS ARE IN INCHES | | INITIALS | DATE |
| TOLERANCES: | | DRAWN JRL | 10/28/10 |
| DECIMALS: .XX ±.13 | ANGLES: ±1° | CHECKED CH | 10/28/10 |
| MATERIAL: SEE NOTES SHEET 1 | | | |
| FINISH: SEE NOTES SHEET 1 | | | |
| CAD GENERATED DRAWING DO NOT MANUALLY UPDATE | | | |
| SCALE: SEE NOTES | SHEET: A | REV: 1 | SHEET 2 OF 2 |
| <p>C&C POWER ENGINEERED POWER PRODUCTS</p> <p>949 N. Larch Ave. - Elmhurst, IL 60126</p> <p>© 2010 C&C POWER, INC. ALL RIGHTS RESERVED</p> | | | <p>THE INFORMATION CONTAINED IN THIS DRAWING IS THE SOLE PROPERTY OF C&C POWER, INC. ANY REPRODUCTION WITHOUT THE WRITTEN CONSENT OF C&C POWER, INC IS PROHIBITED.</p> |